



Step 6

Spars and Sparks

Step 7

Adding the Magic

Step 8

Camping with the Stars

for Cub Scout Packs

Introduction

Dear Beaver Scouters and Cub Scouters,

We are delighted to bring you our eight-step 'Camping with the Stars' resources over the next few weeks. These resources aim to help you and your Colony or Pack to have a fun-filled, youth-centred camping experience in May or June 2018 by building your capacity and confidence in camping step-by-step.

Step 1: **First Pitch**

Plan for camp in small groups; roles for Scouters.

Step 2: **Gearing Up**

Clothing, layers, personal first aid kit, packing an overnight bag, hygiene.

Step 3: **Out and About**

Day activity with the correct gear.

Step 4: **Site and Oversight**

Group gear, Leave No Trace, risk management, site layout.

Step 5: **Food for Thought**

Overnight with food hygiene and prep in small groups.

Step 6: **Spars and Sparks**

Tent pitching, gadget construction, fire-lighting.

Step 7: **Adding the Magic**

Campfire, Scouts' Own, flag ceremony, gear check, revision.

Step 8: **Camping with the Stars**

Revision, get out and camp, review.

We hope you find these resources helpful and informative. Remember, your Scout section may also benefit from camping resources, which are organised slightly differently than those for Beaver Scouts and Cub Scouts.

Wishing you and your Colony or Pack the best of success in the months ahead. Happy camping!

Ian Feighery

Programme Commissioner (Beaver Scouts)

Eilís Molamphy

Programme Commissioner (Cub Scouts)



Spars and Sparks

Tent Pitching

The Cub Scouts will benefit from the experience of setting up their own tents. Scouters can help but the Cub Scouts need to do the work themselves. They will learn lasting lessons from their mistakes and their confidence will grow as they become more successful at the task. Explain to the Cub Scouts that tents are expensive, and must be cared for.

Practice in pitching and striking the tents should be undertaken well prior to going on camp. This allows the Pack to get any teething problems and frustrations out of the way. The Sixer should direct the activity, with some help from Scouters if needed.

Things to bear in mind:

Remove shoes and boots before entering a lightweight tent.

Do not use any SPRAYS (ie spray deodorant) inside or near tent, it can destroy the waterproofing.

Keep all the tent parts together at all times.

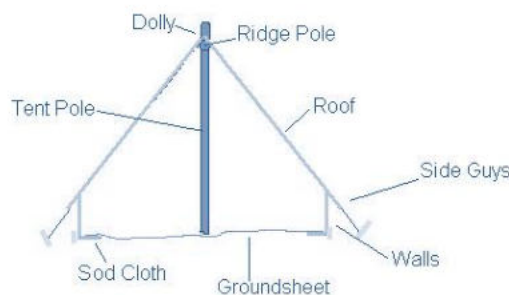
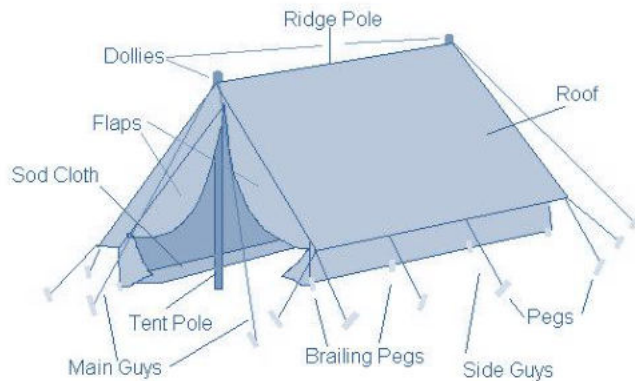

Spars and Sparks

Pitching (putting up) tents

Clear area of sharp objects like stones, sticks, etc.

Look up. See what is overhead. Avoid pitching under large trees.

Make sure that the surrounding area is well drained and level ground.

Keep away from clay soil (puddles and mud when it rains) if possible.



Striking (taking down) tents

Striking and packing away is a reversal of the pitching process.

Sweep out floors to remove any dirt and debris from the tent.

Loosen guy lines.

Pull out the pegs and wipe the mud off on rag.

Remove poles and allow tent to come down.

Fold, roll up or stuff tent depending on manufactures directions.

Try not to pack a wet tent. In some instances this is unavoidable. Wet tents that need to be transported should be packed loosely and set up to dry as soon as possible on return to the Scout Den. Damp tent fabric and guy lines are soon affected by mildew and will start to rot.

Mark and report any damage to the Scout Group Quartermaster so that the tent can be repaired before it is required for the camp.



Spars and Sparks

Pioneering- Square Lashing

While Cub Scouts may have honed their pioneering skills in the Scout Den making simple gadgets by using bamboo and elastic bands, those working on their Tagann badges should be progressing to making basic gadgets from spars and by using lashings. The Cub Scouts must help to 'build' their campsite and take ownership of it.

The illustration below shows how to perform a square lashing.

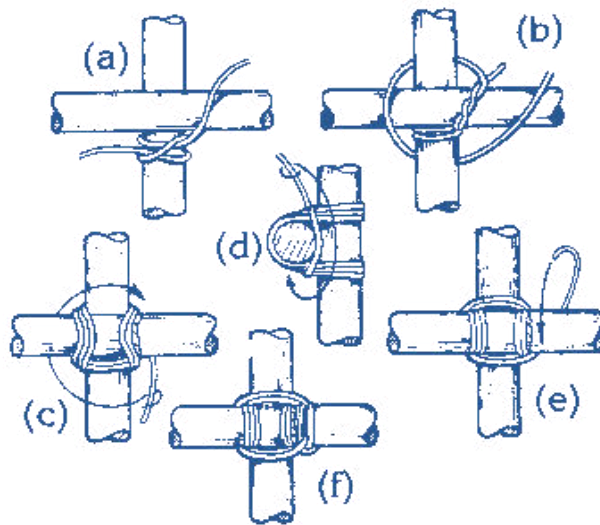

- Begin with a clove hitch underneath the spar to be supported (a).
- Wrap the two ends of the rope together so that the short end is trapped and the clove hitch cannot come undone. Wrap the rope first over one spar, then under the other, pulling tight all the time (b).
- On the second turn round; go inside the previous turn of rope on the top but outside underneath the spars (c).
- After three turns, apply three frapping turns which pull on the rope turns already made, making them even tighter (d).
- Finish off with a clove hitch on the opposite spar to the one on which you started (e)

Spars and Sparks

Gadgets

The illustration below provides several examples of simple gadgets that Cub Scouts could practice making in the scout den for use while on camp.

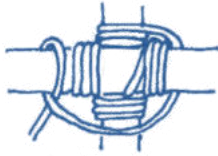

SQUARE LASHING



DIAGONAL LASHING

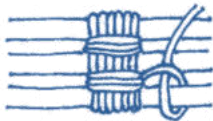

TRIPOD LASHING

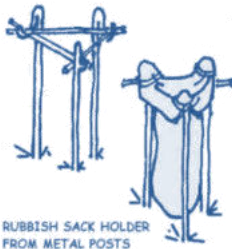

RUBBISH SACK HOLDER FROM METAL POSTS

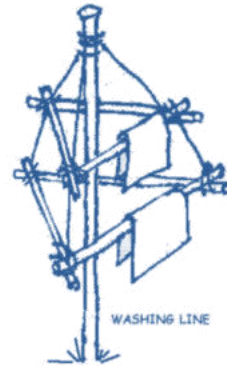

WASHING LINE

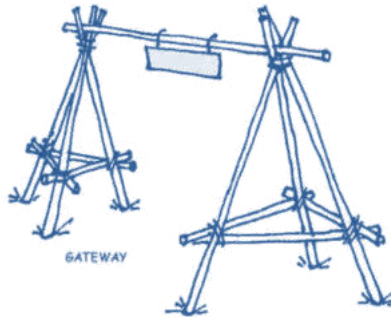

GATEWAY

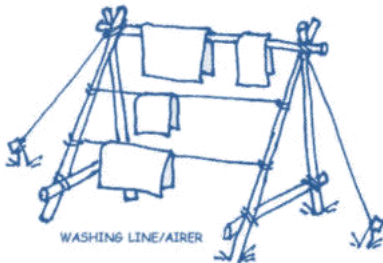

WASHING LINE/AIRER

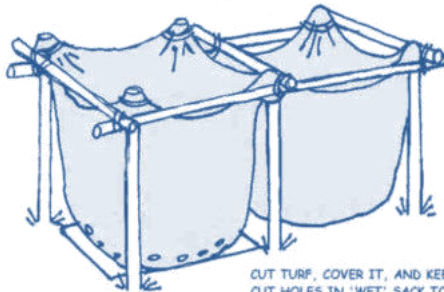

WET AND DRY RUBBISH SACKS

CUT TURF, COVER IT, AND KEEP MOIST
CUT HOLES IN "WET" SACK TO LET WATER DRAIN
FILL "WET" SACK WITH GRASS AND/OR BRAKEN
BURN GRASS WHEN FINISHED

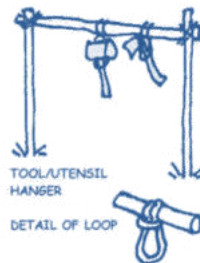

TOOL/UTENSIL HANGER

DETAIL OF LOOP

Spars and Sparks

Fire Lighting

Knowing how to light a fire is an essential skill in Scouting. It's used for cooking and also for warmth. Three elements are needed to make a fire: oxygen, heat and fuel. This is what is known as a fire triangle. Typically, wood is the fuel for a fire, oxygen is provided by the air and the heat comes from a match or spark. If any of these elements are removed, the fire will extinguish.

1. Preparation is vital. Collect plenty of dead, dry wood.
2. Begin small and light with your back to the wind.
3. Feed the fire, don't smother it, and pay particular attention in the early stages.
4. Add additional fuel frequently as needed.
5. Cook over embers, not over flames, such as you would on a barbeque.
6. Never leave the fire unattended
7. Ensure you can extinguish a fire quickly in case of emergency. Keep a bucket of water or sand close at hand.
8. Always return fire sites to their original state, leaving no trace
9. Extinguish the fire and clear the fireplace correctly.

The ideal exercise for Cub Scouts to learn about fire lighting is to have toasted marshmallows as the end result of the process.

Prepare a safe area for the Cub Scouts to light their fires. Let them attempt to light cotton wool balls from a kneeling position. They should have a small bundle of matchstick-sized kindling already gathered prior to lighting the fire. This should be added as soon as the cotton wool catches. Add slightly more fuel so that the fire it will continue to burn for 5 to 10 minutes. Explain how to toast marshmallows on long sticks, holding them above but not directly into the flames. When all the marshmallows are eaten, demonstrate how to extinguish the fire in the correct manner.



Spars and Sparks

Fire Lighting

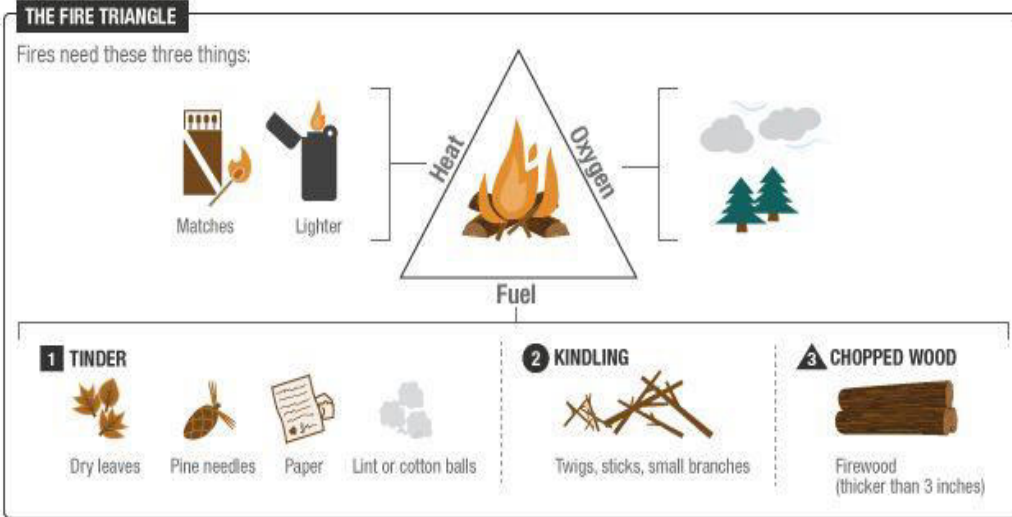

STEP ONE

Make a loose pile of tinder. **1**

TIP: Don't pack too tightly. Air needs to get to all parts of the fire.

STEP TWO

Build a tepee with the kindling **2** around the tinder. Start with the small twigs first.

STEP THREE

Light the tinder from all sides.

TIP: You can blow gently on the fire to get it going. Fires need lots of oxygen.

STEP FOUR

As the fire grows, feed it with branches and eventually firewood. **3**

Enjoy!

STEP FIVE

Put out the fire by cutting one of the sides of the fire triangle. You can do this by covering it with sand or dirt, dousing it with water or letting wood burn out. **Make sure it's cold before you leave!**

Sand or dirt

Water

Let wood burn out

Adding the Magic

Campfire

The campfire is probably the most loved of camping traditions. It's a place to create memories and dreams. The ideal campfire programme lasts about 45 to 60 minutes. This is long enough to keep everyone's attention, but not so long that the Cub Scouts become restless.

A good campfire should be structured with a formal opening, a loud animated and enthusiastic middle, and a defined closing. A good rule of thumb is to "follow the flame." When the flames are high, the energy should match. As the fire dies down, things get calmer. The campfire might also be a suitable venue for sketches and stories.

The campfire should be hosted by a Cub Scouter with the assistance of the Cub Scout who has been given the role of lighting the fire and helping with the planning.

The Campfire Leader should keep the pace rolling along and make sure that all Cub Scouts are involved and that there is a good mix of song types such as songs with lots of movement, while "repeat after me" songs are always hugely popular.

To close out the campfire, choose something appropriately quieter and reflective. Traditionally, the first verse of 'Taps' is the most common closing to all Scouting campfires:

*Day is done.
Gone the sun
From the lake, from the hills, from the sky.
All is well.
Safely rest.
God is nigh.*

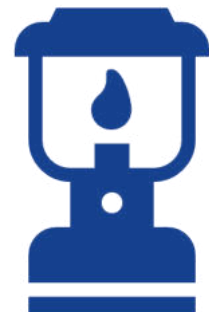

Adding the Magic

Extinguishing the fire, preserving the spirit

After the closing, the Cub Scouts should head back quietly to the mess tent for supper before lights out and bedtime. The campfire lead should always make sure that the fire is safely extinguished before bedtime.

The next morning after the campfire, you may like to collect the ashes from the pit and put these into small individual tubs to be given out to each Cub Scout at the Scouts' Own. The next time the Cub Scout attends a camp with a campfire, they can add their ashes to the fire and again collect the cooled ashes of this new fire, doing likewise for every campfire they attend. This creates a spiritual link between their Scouting experiences.

Campfire songs

There is a vast array of campfire songs and these have been passed down via oral tradition for generations. For those who are new to scouting, or to widen your knowledge base of campfire songs, try the Scouting Ireland Campfire Songs App which has an impressive collection of songs loved by scouts of all ages. Having over 150 songs available on your smartphone will allow you to learn and practice new songs in the scout den with the Cub Scouts so that for your campfire on the pack holiday the pack will have a good old sing song.

Check it out and Download the Scouting Ireland Campfire Songs App from the links below:



Android devices
goo.gl/53w7ob

Apple devices
goo.gl/rwg8dy



Adding the Magic

Scouts' Own

A Scouts' Own is a short inspirational ceremony usually built around a theme. It should be short, usually lasting no longer than 15 minutes. It should be made up of any combination of readings, prayers, reflections and music. Many Scouts' Owns are based on a particular theme, such as friendship, world peace or the world around us.

The Scouts' Own is an opportunity for the Cub Scouts to reflect upon who they are and the core beliefs and values that shape them and what they do. It should be organized and led by the Cub Scouts in a spiritual location of their choosing. The role of the Scouter is to provide guidance. Keep it simple. Use symbols for a pronounced visual experience. Ensure that as many Cubs as possible play a part in the ceremony. If the Cub Scouts wish to write out their thoughts or reflections, put a limit on the number of sentences. Nobody should speak unless absolutely necessary or unless they are reading or singing. If reading, age appropriate language should be used as well as stories and songs. Cub Scouts always enjoy the sense of accomplishment of having carried out a ceremony such as a Scouts' Own.

Some ideas for components of a Scouts' Own include:

- Short poems
- Prayers
- Reflections, quotes, proverbs
- Short parables and fables
- Quotes by Robert Baden-Powell
- Favourite memories
- A moment of silence
- Lighting of candles (battery-operated ones may work best) or torches
- A reflective song you might hear at the campfire (Taps, Scouting Light etc.)
- Handing out of campfire ashes from the night before



Adding the Magic



Flag Ceremony

Some Packs always have a flag ceremony at camp- it may be a tradition within your Scout Group. The flag ceremony is usually conducted at the opening of a camp, as well as every morning at camp. Flag lowering is done at the closing of camp as well as every evening.

At camp, the flag ceremony is best held before breakfast. This is a good way to get everyone up and going before the start of the morning's activities.

A flag on land should not fly at night unless it is fully illuminated. The flag should be lowered at sunset. In the summer, this can be after dinner as part of gathering for the evening's activities.

A recitation of the Cub Scout Promise or Law can happen at the ceremony. When these are recited, everyone must be at alert, making the Scout Sign, and facing forward. A colour party usually consists of one person for breaking and two for lowering.

These ceremonies are normally led by the Camp Chief. They could also be led by the Sixers on a rota basis. You may wish to add to the ceremony by entrusting a Six with providing a reflection (morning ceremony) or summing up their favourite moments of the day (evening ceremony).

NB: If you choose to fly the Irish tricolour flag on your camp, don't forget the expected protocols/ etiquette around this. More information can be found here: goo.gl/aAJRjn



Adding the Magic

Gear Check

Good practice dictates that a gear check precedes the camp, with enough time between the check and the camp for parents to purchase any required items.

Apart from these small 'forgotten' items which the parents may need to purchase at the last minute, the Cub Scout should be familiar with all items in their kit. Camping clothes- and especially boots- should be 'worn in' in the weeks leading up to the camp to prevent problems such as blisters from occurring.



The gear check should be completed by a Scouter with the Cub Scout; the Cub Scout should be able to sort through their kit with ease and know where each piece of personal gear goes.

In order for the Cub Scout to prepare for this gear check, a gear list (an adaptation of one listed in the previous resource) should be provided. The Cub Scouts should be able to 'check off' each item as they pack at home.

Adding the Magic

Sleeping bag and mat

A comfortable night's sleep is determined by the warmth and comfort of the sleeping bag. Cold rising from the ground through the groundsheet of the tent will draw away warmth leading to a restless night's sleep.

If possible, Scouters should also check Cub Scouts sleeping bags at a camp planning meeting before camp to ensure that they are adequate. Scouters should advise parents on the best buys. A sleeping bag will last for many years and an investment in a proper bag at the beginning is always worthwhile. Lightweight festival style summer sleeping bags are not suitable for most camps.

The sleeping mat prevents the transfer of heat by acting as an insulation layer between the Cub Scout and the ground. Sleeping mats have different levels of quality and effectiveness. The cheaper mats have a loose cell structure and will compress easily so that the insulating layer can be quite thin and offer little protection. Yoga mats are not suitable for camping and should not even be considered.

How you store your sleeping bag affects its lifespan. When you arrive home from camp, unzip the bag and air it out for at least 24 hours to make sure it's completely dry. Never store your bag in its stuff sack! It's fine to use a stuff sack or even a compression stuff sack on camp, but when you return home, get your bag out of that confined space, give it a good shake to fluff up the fill material, and then store it in a cool, dry place. Spread it out under your bed, hang it in a wardrobe, or put it in a big, breathable storage bag or pillowcase. Watertight storage bags are also a bad idea. Condensation can build up inside and result in mildew.

STUFF SACK	COMPRESSION SACK	DRY BAG
<p>Ideal For:</p> <ul style="list-style-type: none">• Long-term storage <p>Purpose:</p> <ul style="list-style-type: none">• Preserve loft of insulation	<p>Ideal For:</p> <ul style="list-style-type: none">• Backpacking• Camping <p>Purpose:</p> <ul style="list-style-type: none">• Save space	<p>Ideal For:</p> <ul style="list-style-type: none">• Canoeing• Kayaking• Boating <p>Purpose:</p> <ul style="list-style-type: none">• Keep gear dry

Adding the Magic

Care of your sleeping bag

Washing

- Wash your bag when it gets dirty, or loses a noticeable amount of fill, but not after every trip. This should be done at least once a year. Washing will help restore warmth and breathability so the bag performs like new again.
- For safe and thorough cleaning, head to your local laundry and use a jumbo, large capacity washing machine.
- Be sure to turn the sleeping bags inside out prior to washing. Water will escape through the lining material more easily than it will through the water resistant or waterproof shell material during the spin cycle. During washing, ensure all zippers and the Velcro tab are secured.
- Use warm or cold water, the gentle cycle, and a mild detergent of which you should use as little as possible. Never use fabric softener.

Drying

- If using a tumble dryer, opt for the largest dryer you can find.
- For a down sleeping bag, toss in 6 tennis balls or a clean pair of sneakers to help fluff it up.
- Turn the dial to the lowest/coolest setting. Sleeping bags take anywhere from 2 to 5 hours to dry completely.
- Check the bag periodically to make sure the fabric isn't scorching hot and the insulation isn't bunching or clumping. If it's too hot, the fabric or the synthetic fill can melt.
- To air-dry your sleeping bag, lay it out flat on towels over two portable clothes racks, or dry in a shaded area out of direct sunlight, as excessive exposure to UV will degrade the nylon shell fabric. A warm, dry, windy day provides the perfect conditions for air-drying your sleeping bag.
- Make sure your bag is thoroughly dry before placing it in its storage bag.

Camping with the Stars

Administration

All camps must adhere to **Scouting Ireland's Camping and Adventures in the Out of Doors Policy (SID 77-11)**. Refer to the most up-to-date version of this document.

Make sure that all of your paperwork is in order well in advance of the camp. Insist that where there is no consent form or medication form (where applicable), the Cub Scout will not be able to partake in the camp.

It is good practice to have copies of the Accident/ Incident Report Form printed out for the weekend.

Links to the forms required for camp are listed below:



Activity Consent Form (SIF 11/05)

goo.gl/qG9uGc

Managing Medications Form (SIF 11a/10)

goo.gl/6RxKx8

Accident/Incident Report Form (SIF 10/05)

goo.gl/g3Jj4P



Camping with the Stars

Revision

As the Camp Chief, you may like to have your own checklist ready to tick off by the time the week of the camp comes around, for example:

- Parents informed of drop-off and collection times
- All activities consent forms completed and collated
- All relevant medication forms completed and collated
- Medicines kept/ stored in agreed manner
- Copies of accident report form
- List of Cub Scouts attending
- List of parental and emergency contacts
- Phone and phone charger
- First Aid kits
- Group gear sorted and dropped to site in time for camp
- Activity equipment packed
- Money/ signed cheque for campsite
- Spare personal equipment (you may like to have a spare sleeping bag, etc. in case of accidents)
- Suncream, insect repellent, etc.
- Risk assessment carried out
- Outline of Camp programme and times; washing and cooking rotas

With your checklist all ticked off, all that is left is to ensure your Cub Scout Pack has a camp to remember!



Camping with the Stars

Review

Following the return from your Pack Holiday it is time to review the camp with the Scouters and the Cub Scouts. These reviews should be done in the Cub Scouts Sixes.

Remember the four F's in a review:

- Facts: What happened?
- Feelings: How did you feel it went?
- Findings: What did you learn?
- Future: What would you do better next time?



As well as reviewing the camp programme, events and how everyone got on, the Cub Scouts should also review with their travel cards so see if they undertook their learning objectives as planned. This review of their personal progression in the SPICES is the most important part of the Cub Scout programme. As the camp is the highlight of the scout year, it is a time to award the Turas, Taisteal, Tagann badges.

It is important to take on board reviews of the Cub Scouts when planning the next Pack adventure or camp. Are there areas that could have been improved or unforeseen circumstances that you might be better equipped for next time? A sit-down with the Scouter team allows a more in-depth discussion and this review should also greatly inform planning for future camps.

Remember, it is not a true camping experience if everything goes exactly to plan! The plan is there to guide your Scouters and Cub Scouts, but it is not the end of the world if one or two things didn't happen due to running out of time, etc. Oftentimes, the most memorable parts of camp are the unexpected moments nobody could have planned! As long as everyone got back in one piece, had a fantastic time and- most importantly- are eagerly awaiting their next camp, chalk that down as a success! Know what can be improved, but don't forget to celebrate the successes too!

